

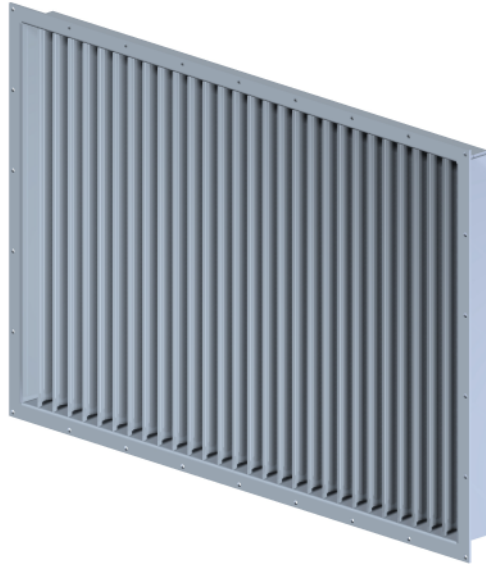

ŻALUZJE Z ODKRAPLACZEM



ZASTOSOWANIE

Wysokowytrzymałe żaluzje z odkraplaczem przeznaczone są do zastosowań okrętowych jako wloty powietrza itp.

DRS-F

Prostokątny, wysokowydajny separator kropel do montażu na grodzi.
Profile wykonane są z wysoko rozciągliwego stopu aluminium, odpornego na sól.
Dostępne w różnych rozmiarach, również na specjalne zamówienie.

DRSL-F

Prostokątny, wysokowydajny separator kropel do montażu na grodzi.
Profile wykonane są z wysoko rozciągliwego stopu aluminium, odpornego na sól.
Żaluzje przeciwwilgociowe wyposażone są w pokrywę na zawiasach z uszczelką neoprenową i bolcami zabezpieczającymi z nakrętkami blokującymi z uchem.
Wykonanie z zawiasami od góry, od dołu lub z boku.
Dostępne w różnych rozmiarach, również na specjalne zamówienie.

KONSTRUKCJA

Wysokowydajny Profil DRS został opracowany i zaprojektowany przez Nyborg.

WYKONANIE

Zewnętrzna ramka zwykle produkowana z ocynkowanej ogniowo stali okrętowej klasy A.
Jako opcja dostępna w całości ze stal i nierdzewnej, również z filtrem.



MIST ELIMINATOR LOUVERS

DRS - F

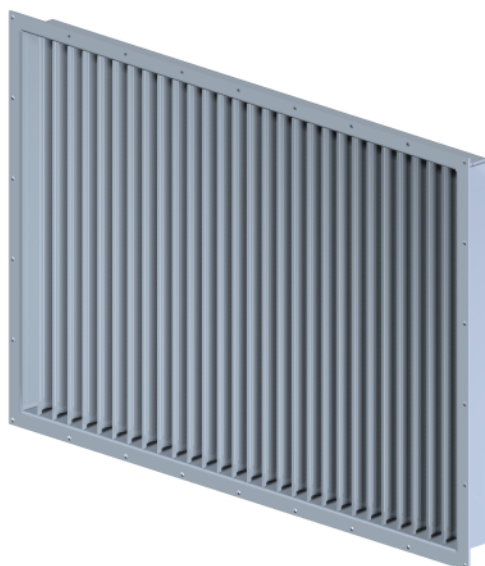

DRSL - F

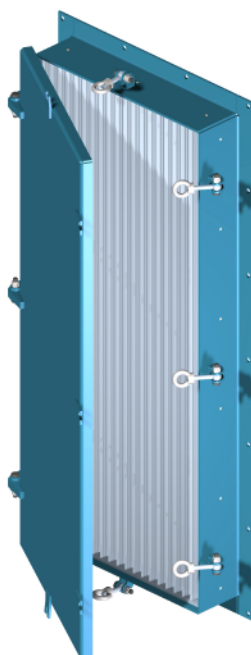

NYBORG - MAWENT

NYBORG-MAWENT S.A.
ul. Ciepła 6, 82-200 Malbork
tel.: +48 55 646 63 00
fax: +48 55 646 63 09
office@nyborg-mawent.com
www.nyborg-mawent.com



NYBORG AS
N-6230 Sykkylven, Norway
tel.: +47 70 25 40 80
fax: +47 70 25 29 08
office@nyborgfan.com
www.nyborgfan.com



NYBORG HIGH EFFICIENCY DROPLETS SEPARATOR PERFORMANCE DATA

DRS

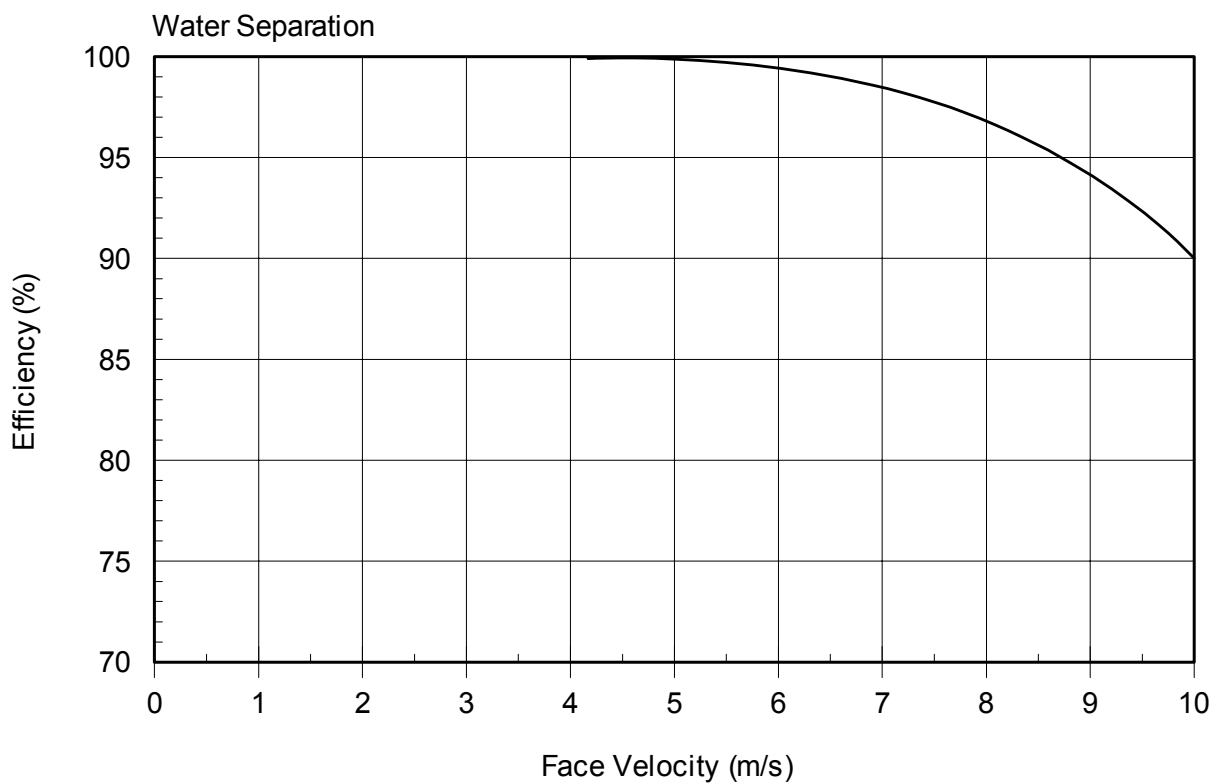
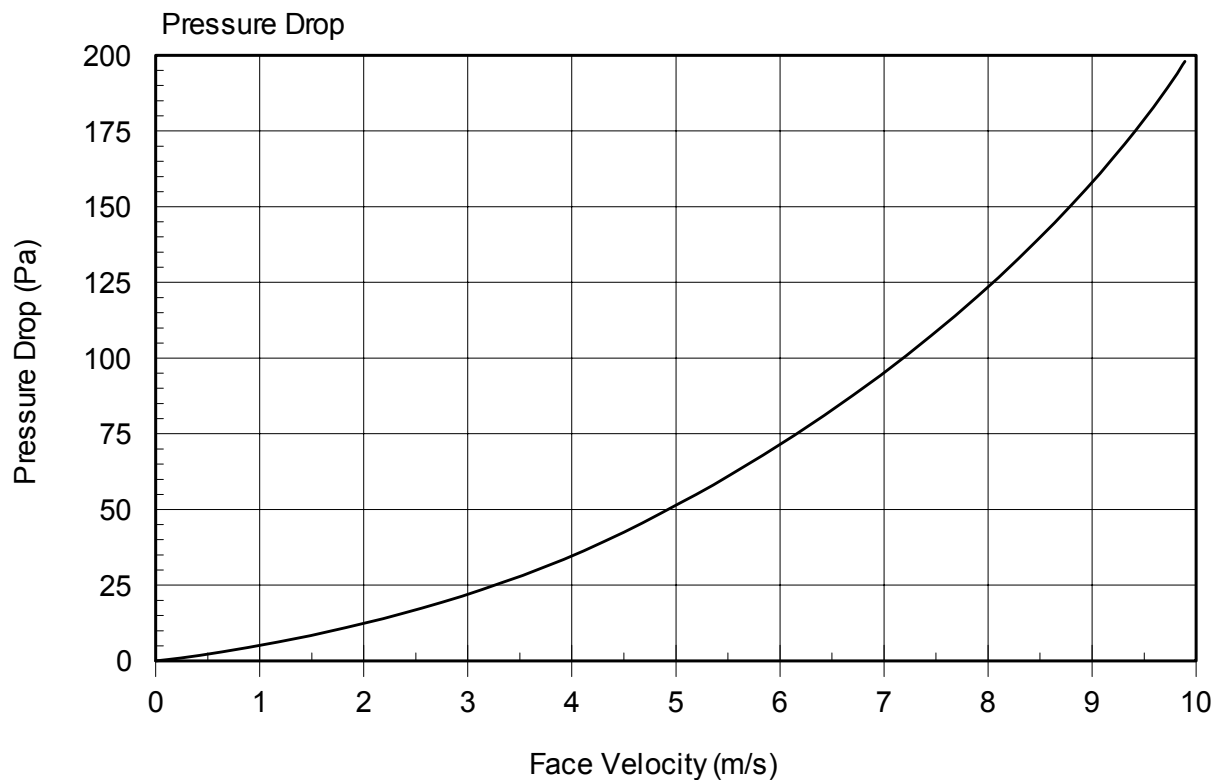



NYBORG SHUTABLE BLADE DAMPER WITH INTEGRATED WEATHER LOUVRE

**SSVent B x H FS /
DRS B x H G**

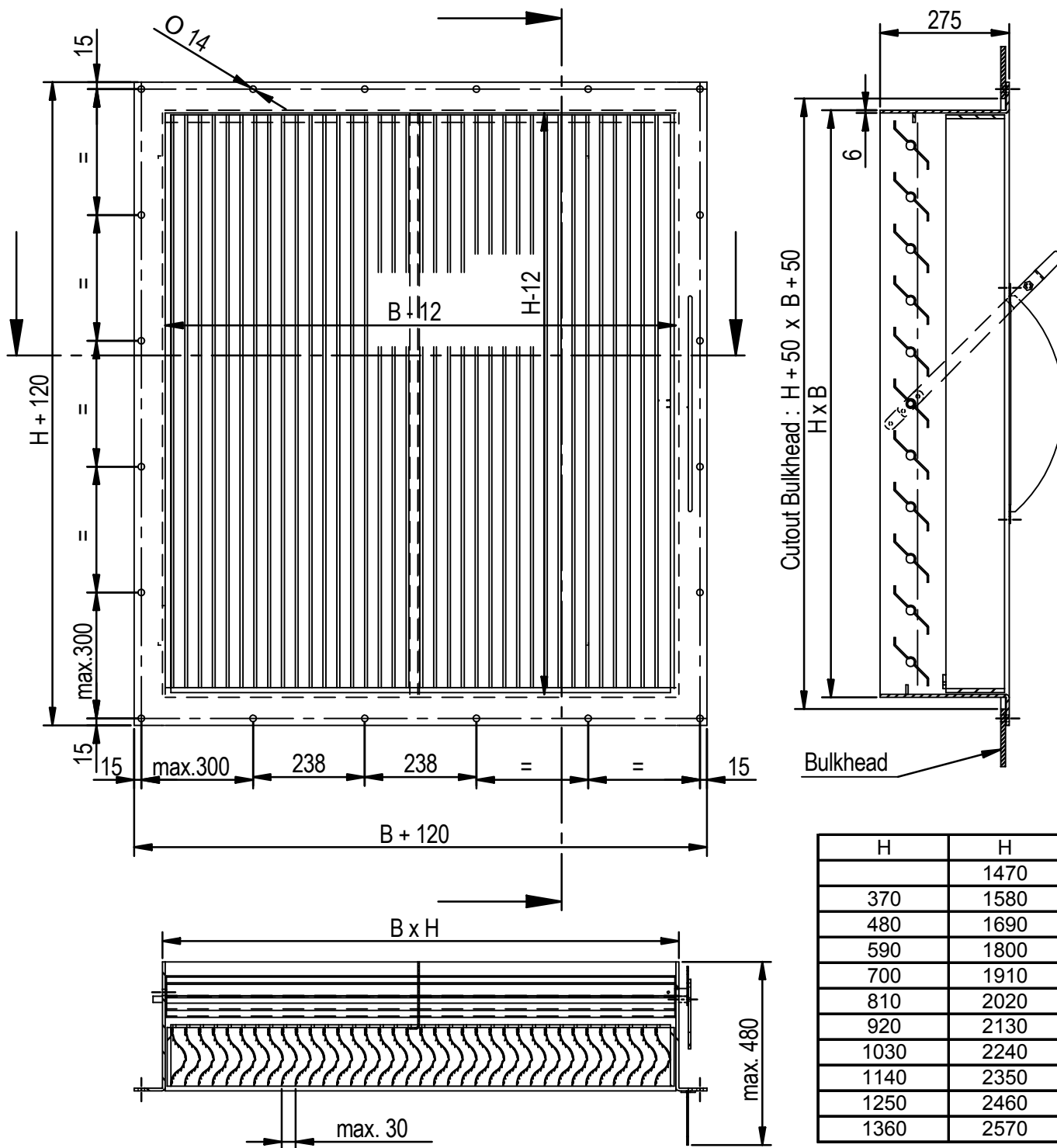

NYBORG BLADE DAMPER SSVent B x H FS , made of hot dipped galv.St.37.
Damper blades and shafts in AISI 316L.
NYBORG WEATHER LOUVRE DRS B x H G, made of high tensile
alum. alloy,salt resistant.

26/03-01
R.Berge
4-2104



NYBORG-MAWENT S.A.
ul. Ciepla 6, 82-200 Malbork
tel.: +48 55 646 63 00
fax: +48 55 646 63 09
office@nyborg-mawent.com
www.nyborg-mawent.com



NYBORG AS
N-6230 Sykkylven, Norway
tel.: +47 70 25 40 80
fax: +47 70 25 29 08
office@nyborgfan.com
www.nyborgfan.com

**SSVent B x H FS /
DRS B x H G**



NYBORG HIGH EFFICIENCY DROPLETS SEPARATOR

**DRS
B x H F**

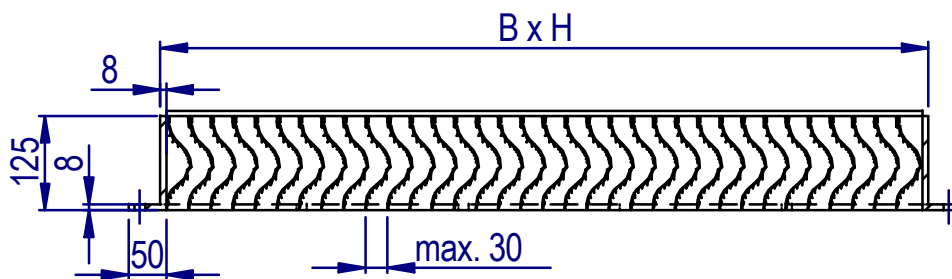
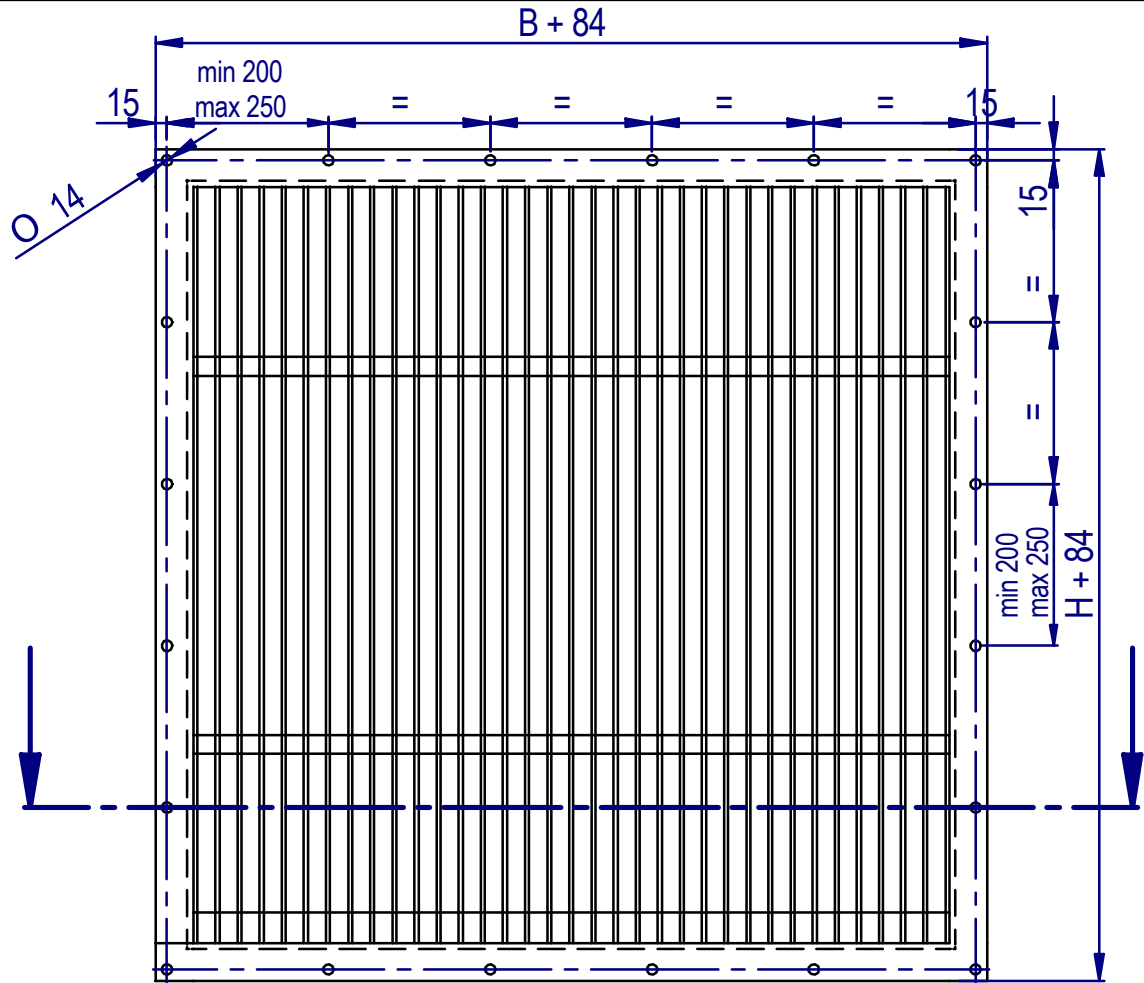

NYBORG HIGH EFFICIENCY DROPLET SEPARATOR
DRS B x H F,
 made of high tensile alum.alloy, salt resistant.
 Bulkhead Cutout : $H + 20 \times B + 20$

4-2101

**29/08-04
R.Berge**



NYBORG - MAWENT

NYBORG-MAWENT S.A.
 ul. Ciepła 6, 82-200 Malbork
 tel.: +48 55 646 63 00
 fax: +48 55 646 63 09
 office@nyborg-mawent.com
 www.nyborg-mawent.com



NYBORG AS
 N-6230 Sykkylven, Norway
 tel.: +47 70 25 40 80
 fax: +47 70 25 29 08
 office@nyborgfan.com
 www.nyborgfan.com

**DRS
B x H F**



NYBORG HIGH EFFICIENCY
DROPLETS SEPARATOR

DRS
B x H G

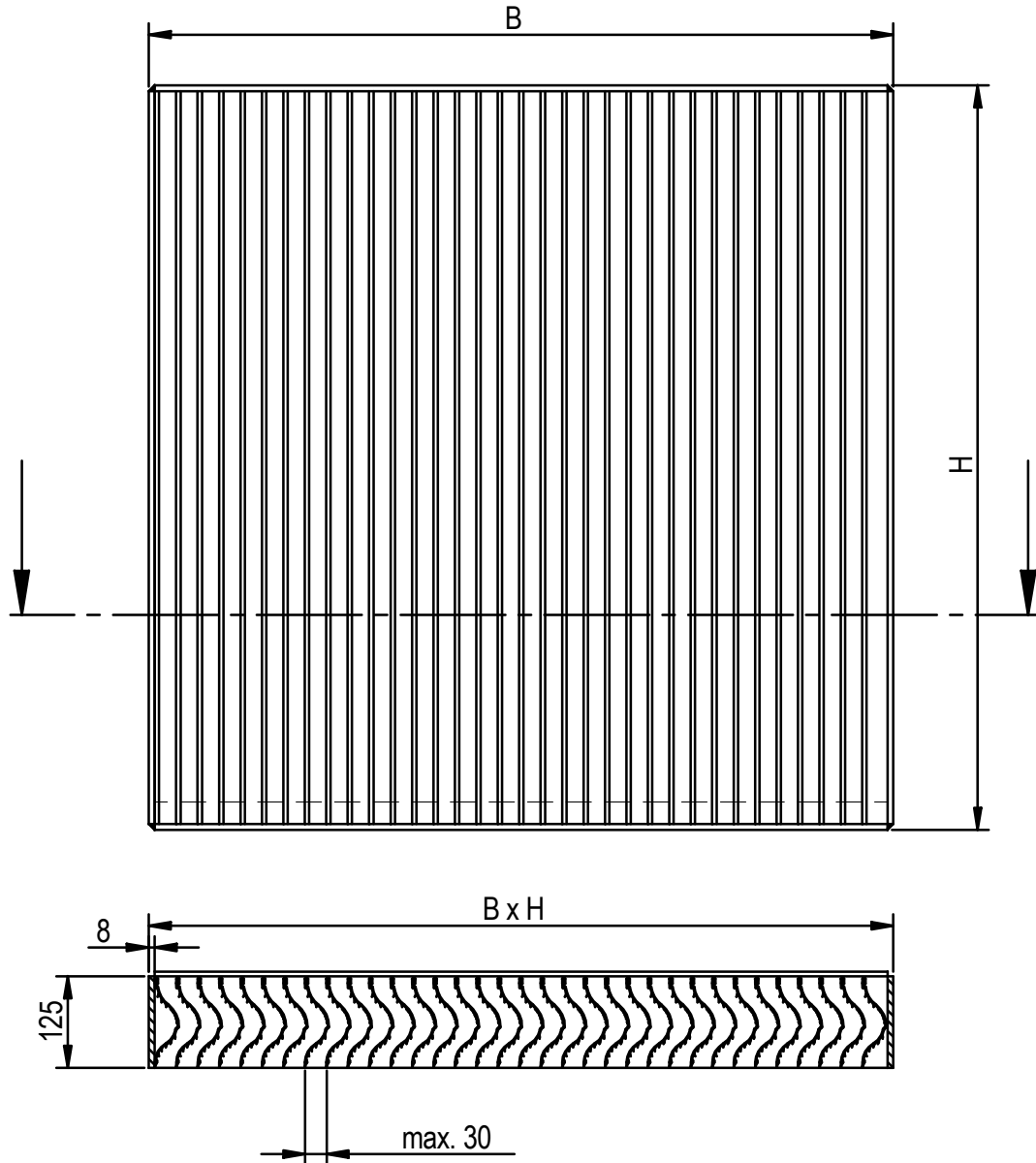

NYBORG HIGH EFFICIENCY DROPLET SEPARATOR
DRS B x H G ,
made of high tensile alum. alloy, salt resistant.

29/08-00

R.Berge
4-2102



NYBORG - MAWENT

NYBORG-MAWENT S.A.
ul. Ciepla 6, 82-200 Malbork
tel.: +48 55 646 63 00
fax: +48 55 646 63 09
office@nyborg-mawent.com
www.nyborg-mawent.com



NYBORG AS
N-6230 Sykkylven, Norway
tel.: +47 70 25 40 80
fax: +47 70 25 29 08
office@nyborgfan.com
www.nyborgfan.com

DRS
B x H G



NYBORG HIGH EFFICIENCY
DROPLETS SEPARATOR WITH FILTER

DRS
B x H FS

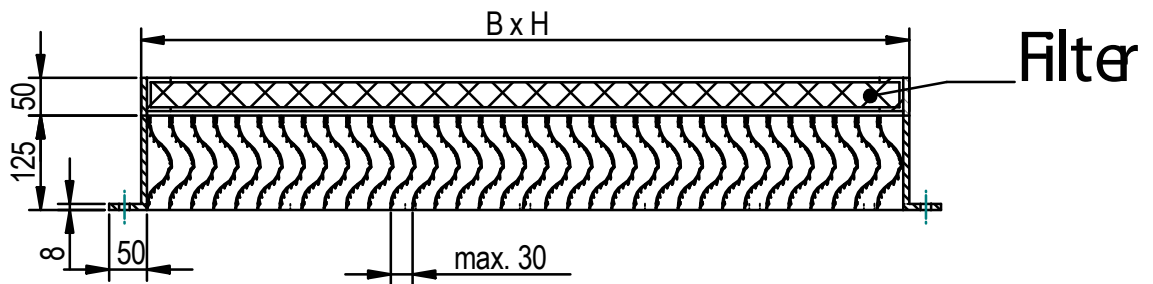
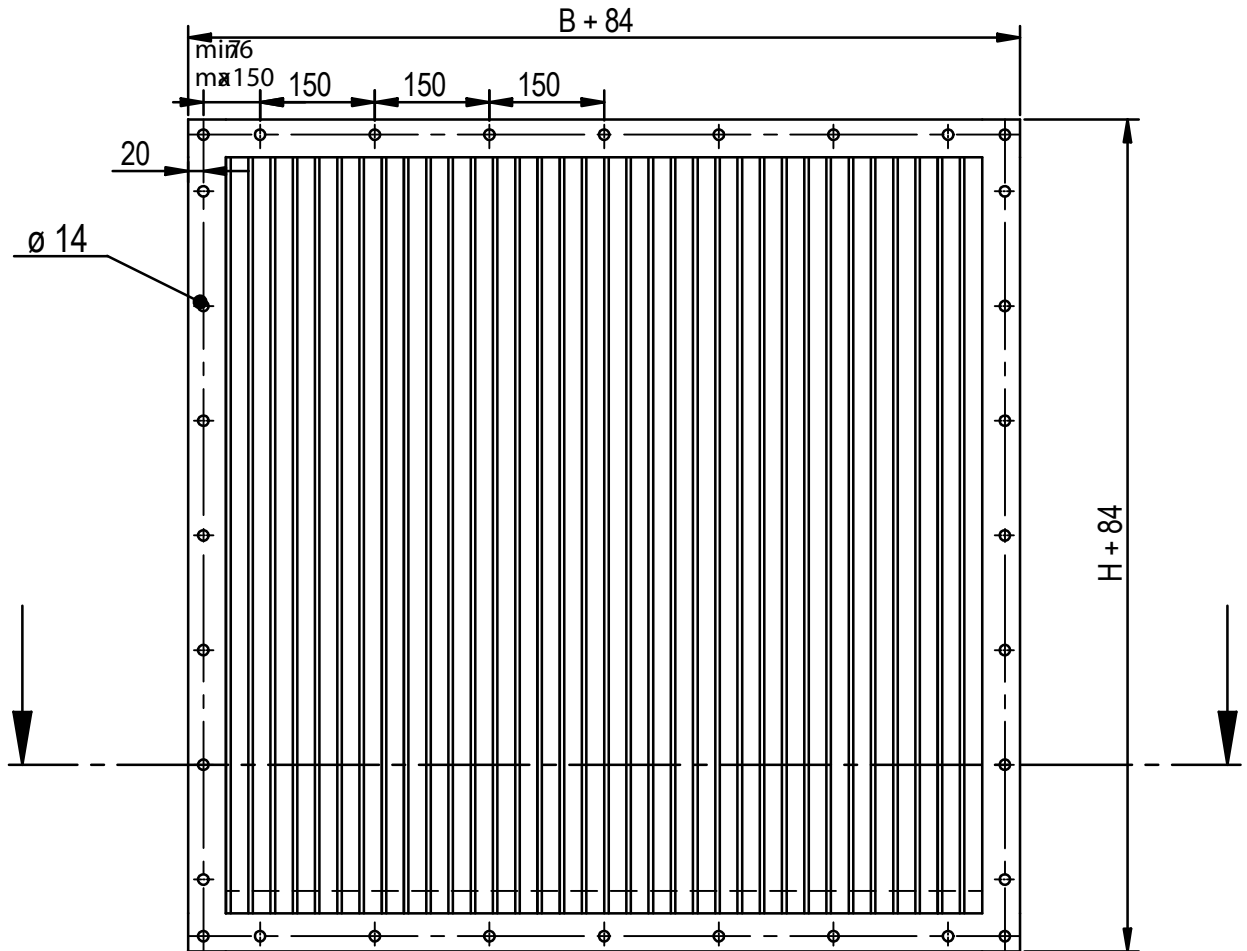

NYBORG HIGH EFFICIENCY DROPLET
SEPARATOR, DRS BxH F,
is made of high tensile alum. alloy, salt resistant.

15/11-02

R.Berge
4-2138



NYBORG - MAWENT

NYBORG-MAWENT S.A.
ul. Ciepla 6, 82-200 Malbork
tel.: +48 55 646 63 00
fax: +48 55 646 63 09
office@nyborg-mawent.com
www.nyborg-mawent.com



NYBORG AS
N-6230 Sykkylven, Norway
tel.: +47 70 25 40 80
fax: +47 70 25 29 08
office@nyborgfan.com
www.nyborgfan.com

DRS
B x H FS



WEATHER LOUVRE WITH VERTICAL BLADES AND HINGED COVER

DRSL
B x H F

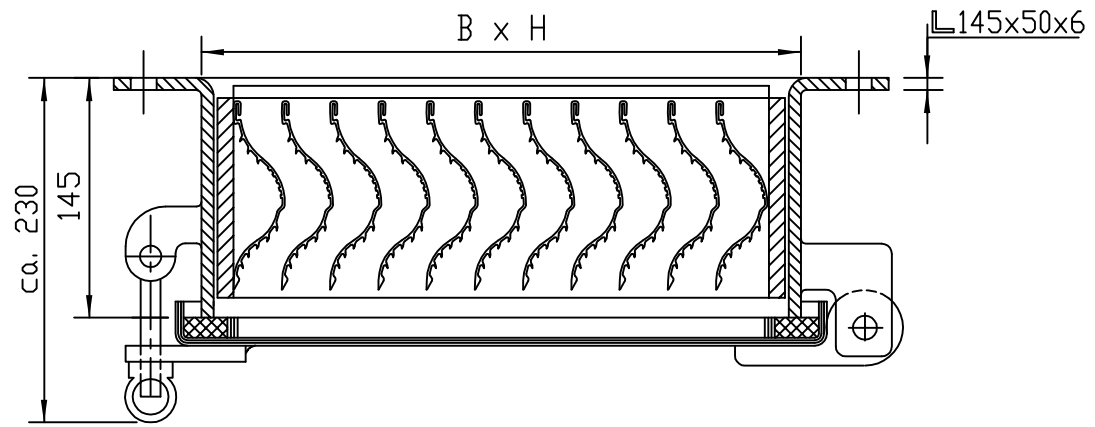
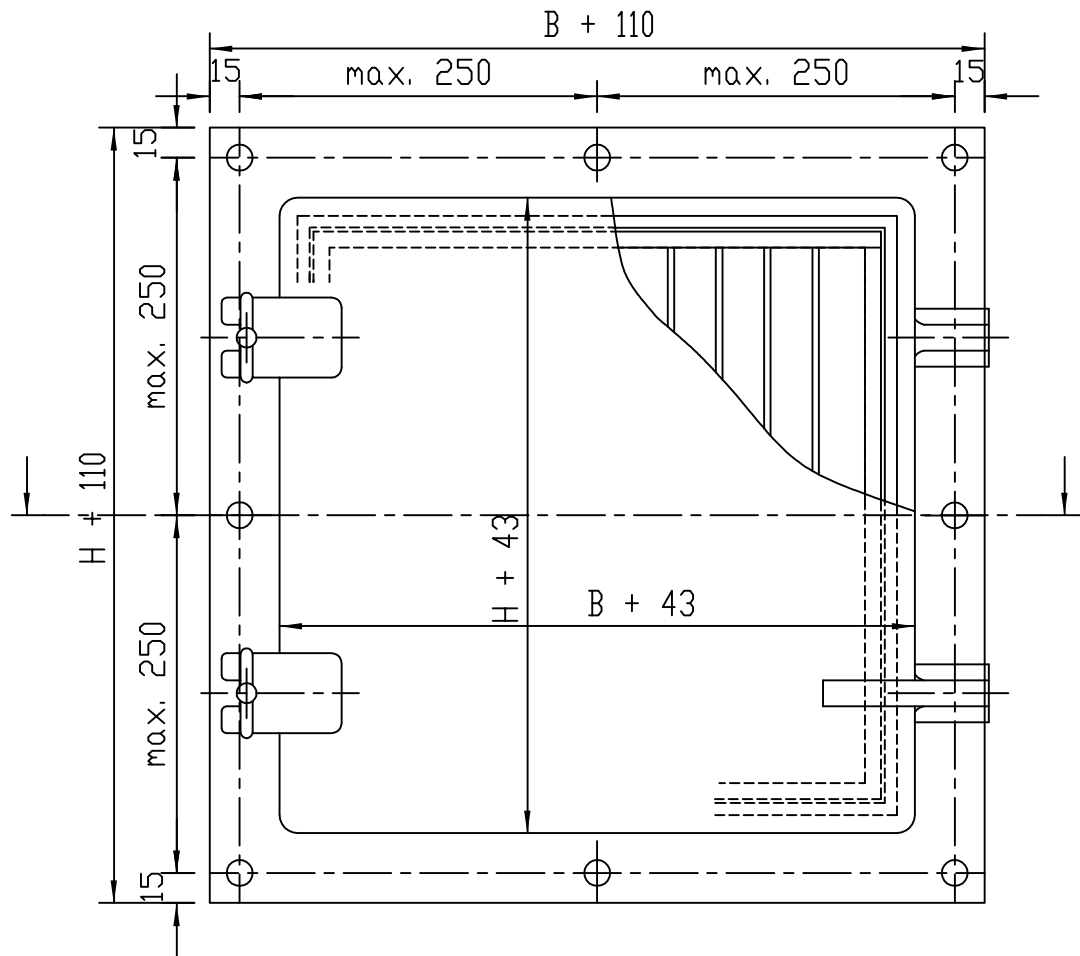

Weather Louvre with Vertical Blades and Hinged Cover

- * The Outer Flanged Frame :Matl. Hot Dipped Galv. Steel.
- * The Inner Frame c/w Vertical Blades : Matl. : Alum. Alloy.
- * Heavy Duty Neoprene Gasket. * Top- or Sidehinged Cover.
- * Hinges and Screw Joints in Stainless Design.

Date : 01.09.2000
Tegn : 4-1459
Name : R.Berge

NYBORG - MAWENT
ul. Ciepla 6, 82-200 Malbork
tel.: +48 55 646 63 00
fax: +48 55 646 63 09
office@nyborg-mawent.com
www.nyborg-mawent.com



NYBORG AS
N-6230 Sykkylven, Norway
tel.: +47 70 25 40 80
fax: +47 70 25 29 08
office@nyborgfan.com
www.nyborgfan.com

DRSL
B x H F

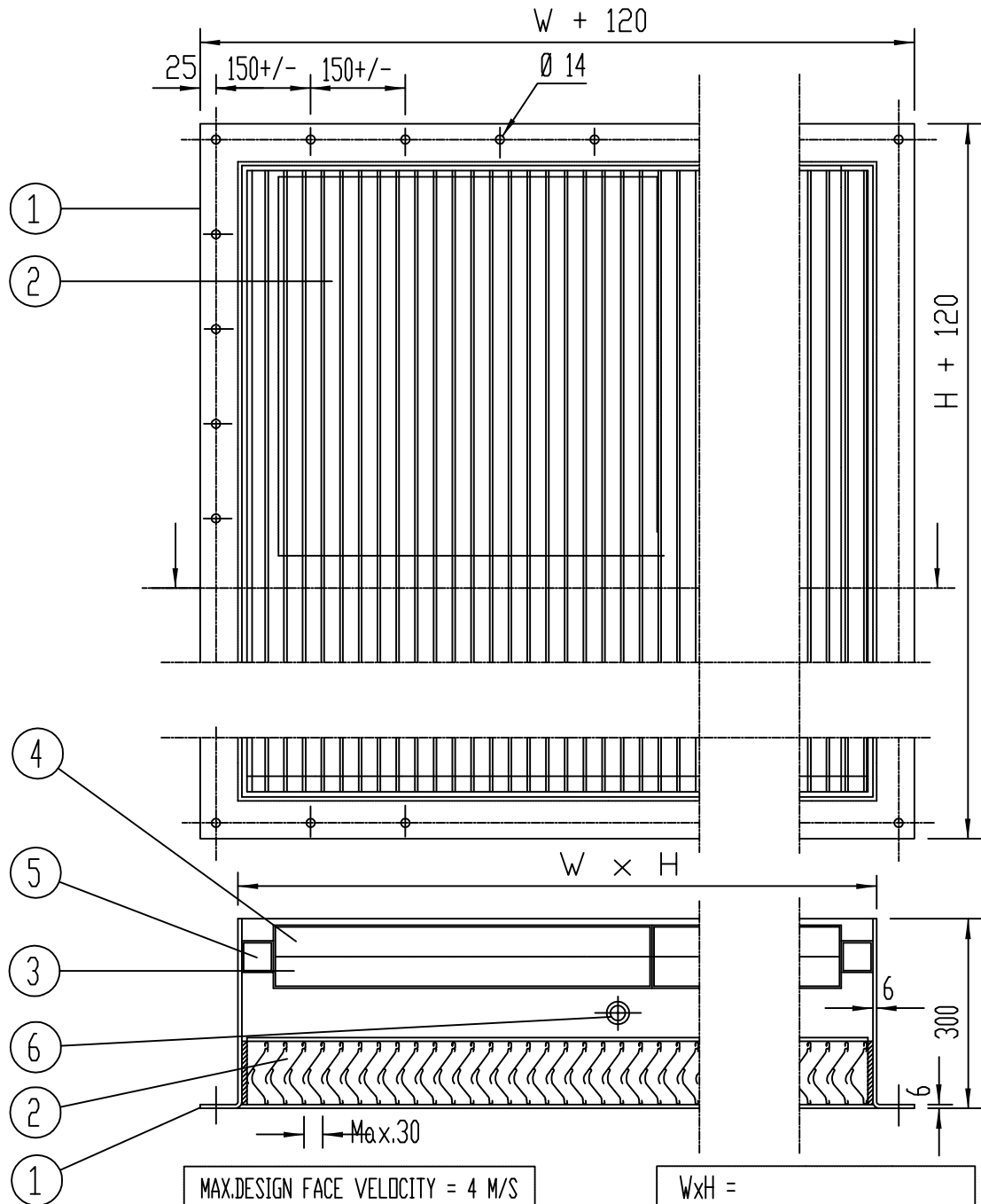

NYBORG INTAKE FILTRATION SYSTEM 3-STEPS.FOR MARINE APPLICATIONS

SRVF
W x H F



| ITEM NO. | DESCRIPTION | MATL. | REMARKS |
|----------|---|--------------|-------------------|
| 1 | FILTER HOUSING, ALL-WELDED | AISI 316 | |
| 2 | HIGH EFFICIENCY WEATHER LOUVRE/ DROPLET ELIMINATOR,1-STEP | ALUM.ALLOY | EXTRUDED PROFILES |
| 3 | FILTER,2-STEP.CASSETTE SYSTEM,600x600x100MM(WxHxD) | SYNTH.FIBRES | EU4,SEP.EFF. 90% |
| 4 | FILTER,3-STEP.INTEGRATED IN ITEM NO.3 | AS ITEM NO.3 | AS ITEM NO.3 |
| 5 | DRAIN SYSTEM OF FILTER CASSETTES.PART OF FILTER HOUSING | AISI 316 | VERTICAL SQ.PIPES |
| 6 | DRAIN SOCKET AT FILTER HOUSING BOTTOM | AISI 316 | |

30.04.96

E.Nyborg

4-1214



NYBORG - MAWENT

NYBORG-MAWENT S.A.
ul. Ciepla 6, 82-200 Malbork
tel.: +48 55 646 63 00
fax: +48 55 646 63 09
office@nyborg-mawent.com
www.nyborg-mawent.com



NYBORG AS
N-6230 Sykkylven, Norway
tel.: +47 70 25 40 80
fax: +47 70 25 29 08
office@nyborgfan.com
www.nyborgfan.com

SRVF
W x H F